

Software Defined Radio

Cumberland Valley Amateur Radio Club
18 March 2010 meeting topic

By D. Daniel McGlothin KB3MUN

Software Defined Radio

I know how to spell
SDR, but what
does it mean?

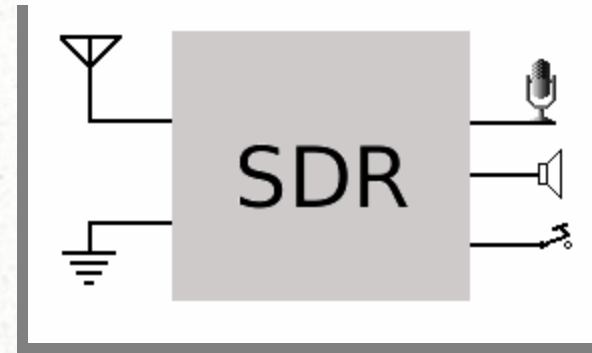

Software Defined Radio

An SDR is in general a radio that has:

- primary functionality defined in software
- DSP algorithms implemented in configurable hardware and/or PC software

Scotty Cowling WA2DFI, from 2008 Dayton Presentation "Hands-On Software Defined Radio"
http://www.hamsdr.com/WA2DFI/Hands_On_SDR_%20Dayton_2008_v0_9.ppt

Software Defined Radio

An SDR is ***not***:

- A computer controlled conventional radio
- A conventional radio with a GUI integrated into its front panel
- A superhet rig with an AF-DSP

Scotty Cowling WA2DFI, from 2008 Dayton Presentation "Hands-On Software Defined Radio"
http://www.hamsdr.com/WA2DFI/Hands_On_SDR_%20Dayton_2008_v0_9.ppt

SDR, without the math

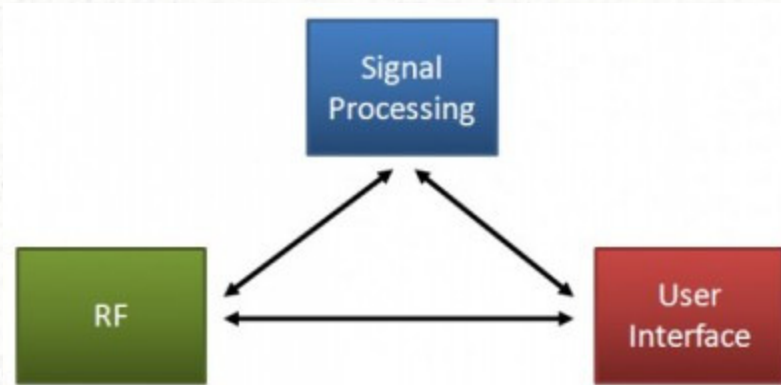

Any radio has 3 parts:

- RF part
- Signal Processing
- User Interface

SDR, without the math

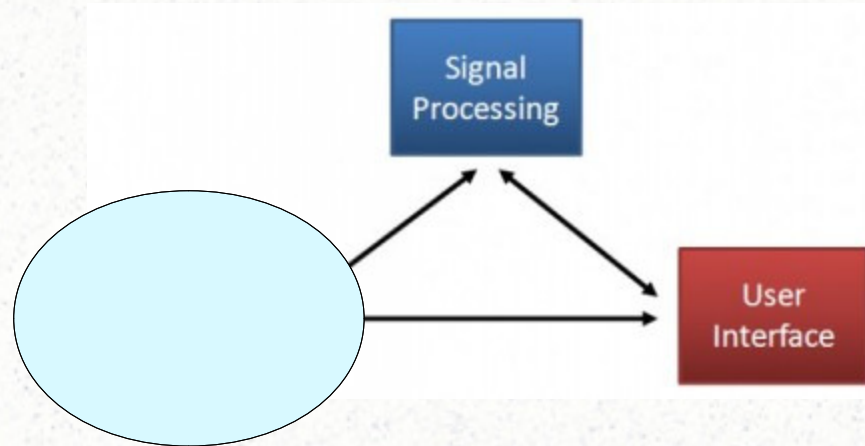

The RF component transforms high frequency signals into baseband signals or vice versa. Parts of the RF component are filters, mixers, amplifiers, oscillators, etc.

SDR, without the math

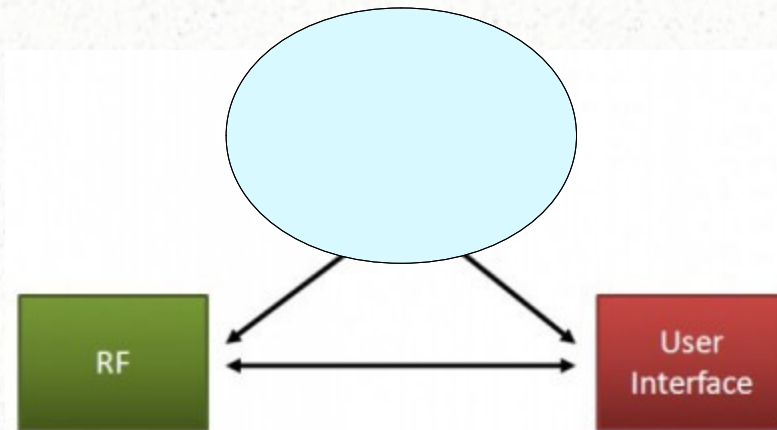

The baseband signal is processed / generated in the Signal Processing component. In this component we will find functionality taking charge of modulation, demodulation, NF filtering, noise reduction, etc.

SDR, without the math

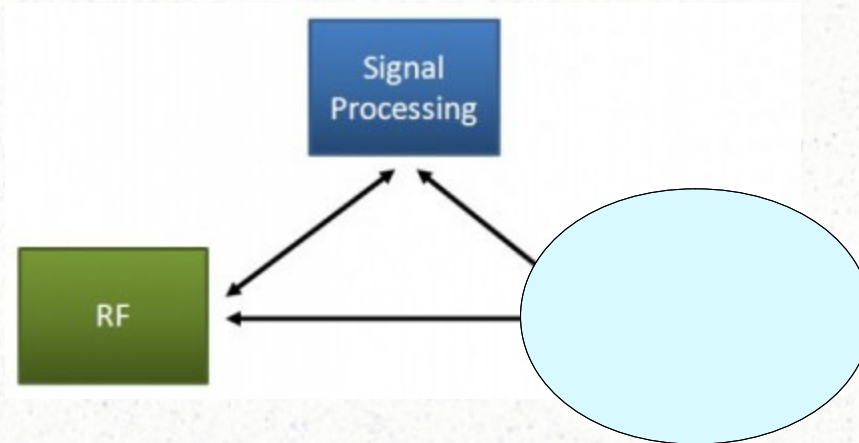

The User Interface (UI) is the command and control unit of the radio. It's the frontend to the (human) operator. The user interface might consist of buttons, knobs, LEDs or just a PC screen.

SDR, without the math

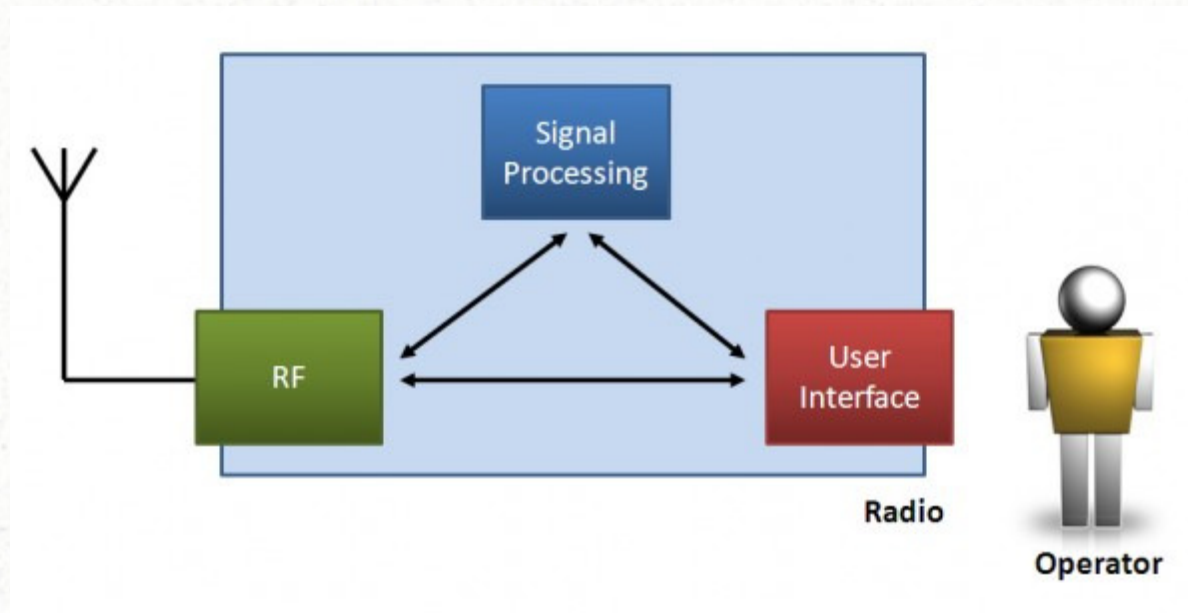

The classic all-in-one-box radio

<http://www.dh1tw.de/understanding-the-sdr-concept>

SDR, without the math

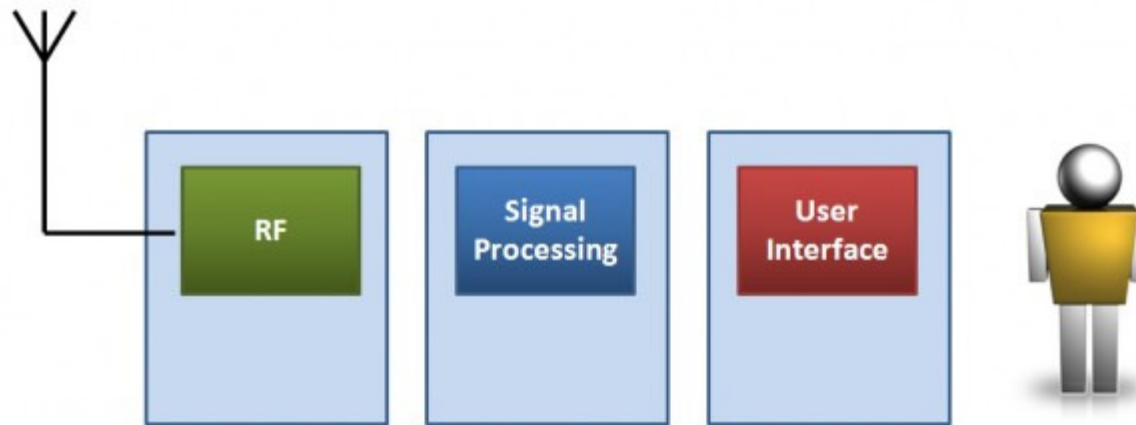

The SDR approach to the 3 parts:

- Physical Independence
- Logical Independence

SDR, with a bit of the math

Quadrature Signal
terms:

- j-operator
- complex
- imaginary
- real
- orthogonal
- $\sqrt{-1}$

SDR, with a bit of the math

Complex Numbers, a mechanical analogy

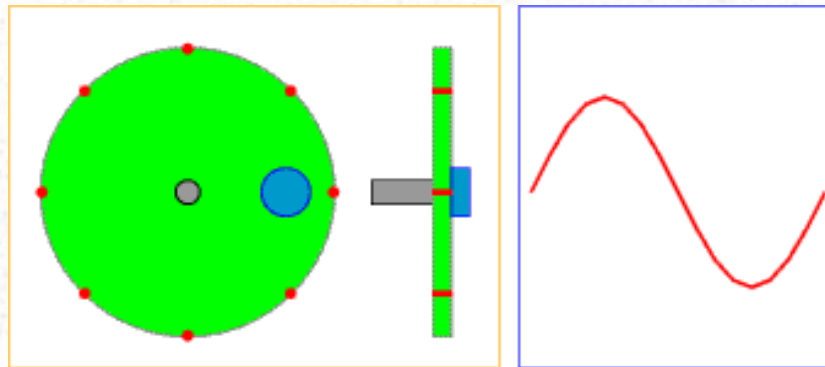

http://www.st-andrews.ac.uk/~www_pa/Scots_Guide/info/signals/complex/cmplx.html

SDR, with a bit of the math

Complex Numbers, a mechanical analogy

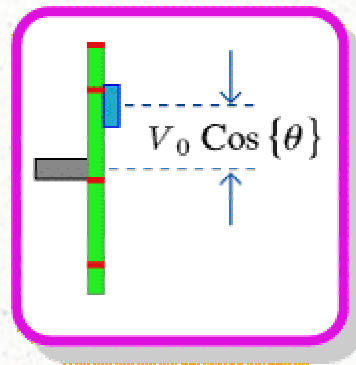
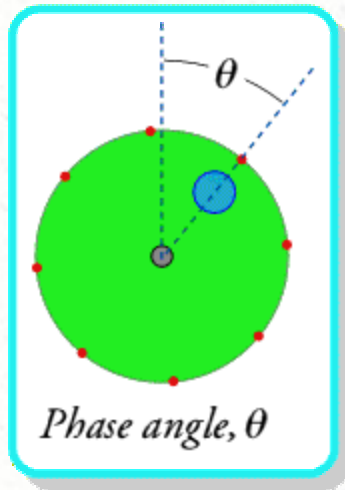

'Real' part (i.e. the visible part) = $V_0 \cos\{\theta\}$

'Imaginary part (we can't see) = $V_0 \sin\{\theta\}$

The complete 'complex' value then described as:

$$V_0 \cos\{2\pi ft\} + jV_0 \sin\{2\pi ft\}$$

or

$$V_0 \exp\{j2\pi ft\}$$

SDR, with a bit of the math

Complex Numbers, another analogy

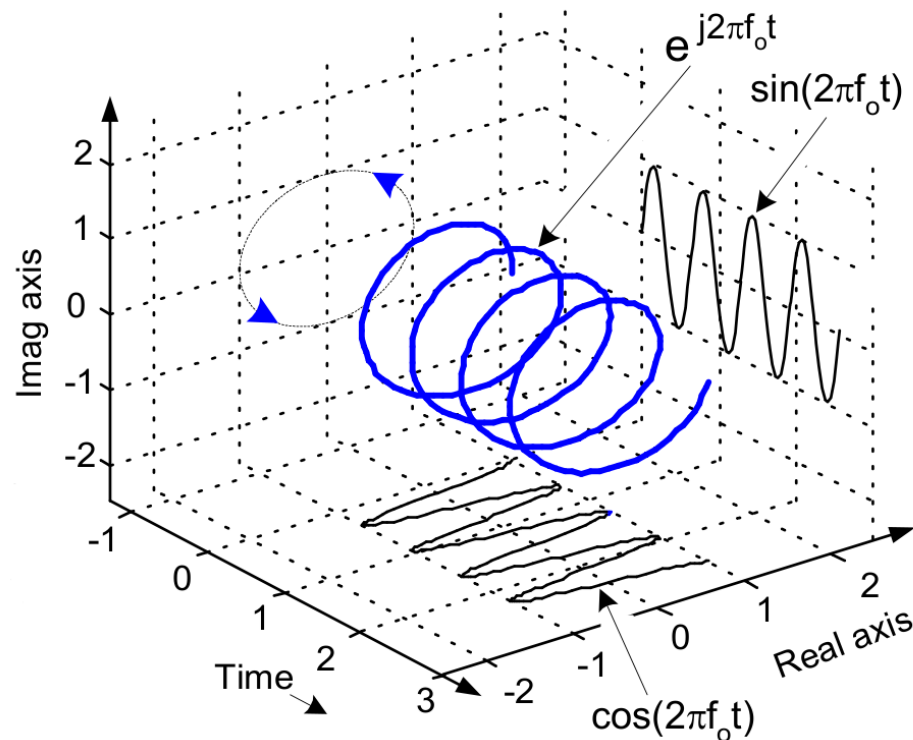

SDR, with a bit of source code

```
void make_fft3_all(void)
{
int ja,jb;
int i,iw,j,k,m,p0,ss,poffs;
int mm, ia, ib, ic, jr, pa, pb, pc;
float t1,t2,t3,t4,x1,x2;
float r1,r2,r3,r4;
float *z;
mm=twice_rxchan;
for(ss=0; ss<genparm[MIX1_NO_OF_CHANNELS]; ss++)
{
poffs=ss*mm*timf3_size;
pc=fft3_pa+ss*mm*fft3_size;
z=&fft3[fft3_pa+ss*mm*fft3_size];
if(mix1_selfreq[ss] >= 0)
{
// Frequency no ss is selected.
if(sw_onechan)
{
pa=timf3_px;
pb=(pa+fft3_size)&timf3_mask;
ib=fft3_size-2;
for( ia=0; ia<fft3_size/2; ia++)
{
ib+=2;
t1=timf3_float[poffs+pa ]*fft3_window[2*ia];
t2=timf3_float[poffs+pa+1]*fft3_window[2*ia];
t3=timf3_float[poffs+pb ]*fft3_window[2*ia+1];
t4=timf3_float[poffs+pb+1]*fft3_window[2*ia+1];
x1=t1-t3;
fft3_tmp[2*ia ]=t1+t3;
```

```
x2=t4-t2;
fft3_tmp[2*ia+1]=t2+t4;
pa=(pa+2)&timf3_mask;
pb=(pb+2)&timf3_mask;
fft3_tmp[ib ]=fft3_tab[ia].cos*x1+fft3_tab[ia].sin*x2;
fft3_tmp[ib+1]=fft3_tab[ia].sin*x1-fft3_tab[ia].cos*x2;
}
asmbulk_of_dif(fft3_size, fft3_n,
fft3_tmp, fft3_tab, yieldflag_ndsp_fft3);
for(ia=0; ia < fft3_size; ia+=2)
{
ib=2*fft3_permute[ia];
ic=2*fft3_permute[ia+1];
z[ib ]=fft3_tmp[2*ia ]+fft3_tmp[2*ia+2];
z[ic ]=fft3_tmp[2*ia ]-fft3_tmp[2*ia+2];
z[ib+1]=fft3_tmp[2*ia+1]+fft3_tmp[2*ia+3];
z[ic+1]=fft3_tmp[2*ia+1]-fft3_tmp[2*ia+3];
}
}
else
{
pa=timf3_px;
pb=(pa+2*fft3_size)&timf3_mask;
ib=fft3_size-2;
for( ia=0; ia<fft3_size/2; ia++)
{
ib+=2;
t1=timf3_float[poffs+pa ]*fft3_window[2*ia];
t2=timf3_float[poffs+pa+1]*fft3_window[2*ia];
t3=timf3_float[poffs+pb ]*fft3_window[2*ia+1];
t4=timf3_float[poffs+pb+1]*fft3_window[2*ia+1];
```

A portion of one of the FFT routines from the LINRAD source code.

SDR, with a bit of hardware

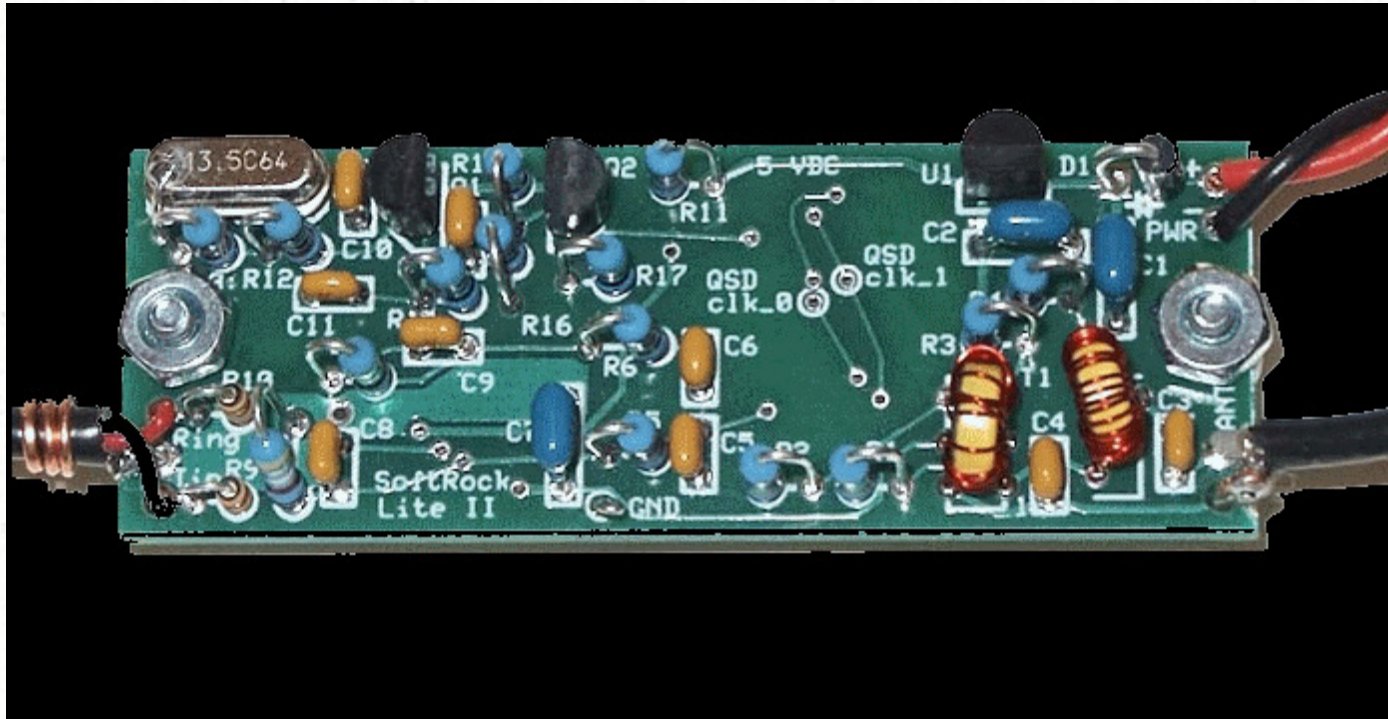

Softrock Lite II kit (assembled)

by Tony Parks KB9YIG

SDR, with a bit of hardware...

KB9YIG.com - Your Source for SoftRock Radio Kits - Mozilla Firefox

File Edit View History Bookmarks Tools Help

http://www.kb9yig.com/

KB9YIG.com - Your Source for S...

Tony Parks, KB9YIG

Your Source for SoftRock Radio Kits

Home Contact Admin

<input type="checkbox"/> 160m SoftRock Lite II Receiver Kit	\$15.00 each	Check back soon.
<input type="checkbox"/> 80m SoftRock Lite II Receiver Kit	\$15.00 each	Check back soon.
<input type="checkbox"/> 40m SoftRock Lite II Receiver Kit	\$15.00 each	Check back soon.
The 40m SoftRock Lite II kit provides a simple to build SDR receiver with a fixed center frequency of approximately 7.055 MHz. When used with a sound card that can sample at 96 kHz, the band coverage is from 7.007 MHz to about 7.103 Mhz		
<input type="checkbox"/> 40m SoftRock Lite II Receiver (Assembled, Tested, Warranty)	\$38.00 each	
<input type="checkbox"/> Upgraded 30m SoftRock Lite II Receiver Kit	\$18.00 each	
<input type="checkbox"/> Upgraded 30m SoftRock Lite II Receiver (Assembled, Tested, Warranty)	\$41.00 each	
<input type="checkbox"/> Upgraded 20m SoftRock Lite II Receiver Kit	\$18.00 each	
<input type="checkbox"/> Upgraded 20m SoftRock Lite II Receiver (Assembled, Tested, Warranty)	\$41.00 each	

Your Cart
Your cart is empty.

Total kits shipped over a four year period is in excess of 20,000 kits. Not too bad for a retired guy with some help from my wife.
73,
Tony Parks
<http://www.kb9yig.com>

Done

...and Heathkit-style instructions

Softrock Lite II Builders' Notes - Mozilla Firefox

File Edit View History Bookmarks Tools Help

http://www.wb5rvz.com/sdr/sr_lite_ii/

Softrock Lite II Builders' Notes

Softrock Lite II Project

[Home](#) [Bill of Materials](#) [Power Supply](#) [Local Oscillator](#) [Divider](#) [Operational Amplifiers](#) [Band Pass Filter](#) [Mixer](#)
[External Connections](#) [Comments](#) [Acronyms](#) [Revisions as of 12/22/2009](#) [WB5RVZ Main Website](#)

Search: Search selected SDR sites

Project Introduction

General

These notes have been compiled into a PDF file by Philippe F6CZV for those who would prefer to have [a single, printable source of the instructions](#).

The Softrock Lite II, the sequel to the [SR Lite V6.2 series](#), provides an economical entry-level kit for the ham or SWL who wants to experiment with Software Defined Radio (SDR).

The Lite II circuit board size is 2.5 inches by 0.9 inches. All SMT components are mounted on the bottom of the board .

Ordering Information

Prices and availability of the kit and its options are found at the [Softrock Ordering Website](#).

As of January 2009, the offerings in this series will include (links are to schematics in Yahoo Groups files folder):

- [40m kit option \(the example used herein\)](#)
 - 40m kit will tune the following ranges:

Read i4.ytimg.com

Softrock Lite II

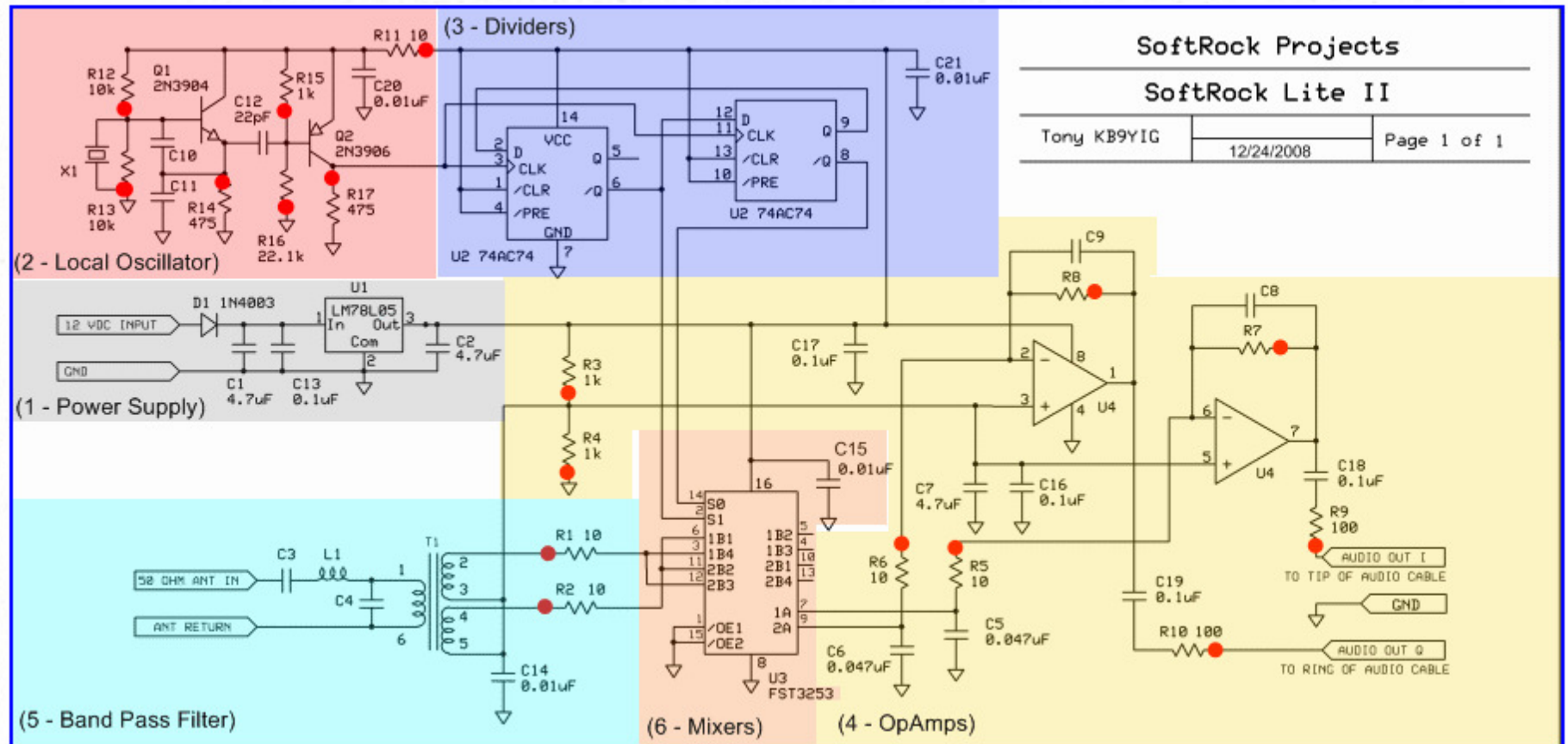

SoftRock Projects

SoftRock Lite II

Tony KB9YIG

12/24/2008

Page 1 of 1

<http://groups.yahoo.com/group/softrock40/>

<http://kb9yig.com/>

http://www.wb5rvz.com/sdr/sr_lite_ii/

Softrock Lite II – Power Supply

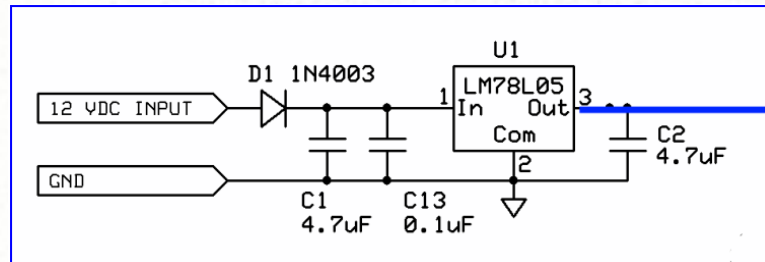

Theory of Operation

This stage provides the +5 volt power rail for the radio. The incoming voltage (from 9 - 12 Vdc) is regulated by U1 to a nominal 5 Vdc (4.5 - 5.1 Vdc range). D1 serves to protect the circuit from accidentally reversed polarity.

Softrock Lite II – Local Oscillator

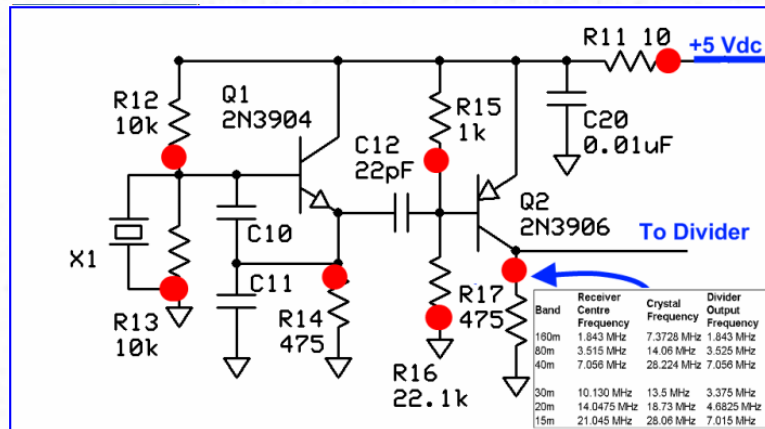

Theory of Operation

The Local Oscillator stage implements a basic Colpitts Crystal Oscillator with a buffer stage to increase the signal level. The oscillator produces a signal that is at the crystal's specified fundamental frequency.

On the 30m, 20m, 15m receivers, the Local Oscillator produces a signal that is 4/3 times the desired center frequency as opposed to the 4x the center frequency output for the lower band models (40m 80m, 160m).

Band	Receiver Centre Frequency	Crystal Frequency	Divider Output Frequency
160m	1.843 MHz	7.3728 MHz	1.843 MHz
80m	3.515 MHz	14.06 MHz	3.525 MHz
40m	7.056 MHz	28.224 MHz	7.056 MHz
30m	10.130 MHz	13.5 MHz	3.375 MHz
20m	14.0475 MHz	18.73 MHz	4.6825 MHz
15m	21.045 MHz	28.06 MHz	7.015 MHz

"Subharmonic" works like this:- The LO outputs 13.5MHz. That goes to the dividers /4, resulting in 3.375MHz being fed to the mixer. At the mixer, a strong 3rd harmonic is present $3.375 \times 3 = 10.125\text{MHz}$. The Bandpass filter (BPF) severely attenuates any signals centered around the 3.375MHz fundamental frequency and first harmonic, but allows 30m signals centering around the third harmonic of the 3.375MHz LO output. The result is that the mixer is dealing with signals centering on 10.125MHz, as though the dividers were passing 10.125 to the mixer. BPFs are all that stop Softrocks from working on unwanted frequencies!

Softrock Lite II – Dividers

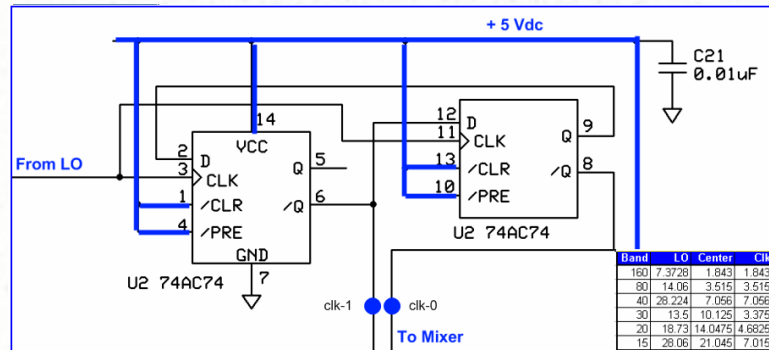

Band	LO	Center	Clk
160	7.3728	1.843	1.843
80	14.06	3.515	3.515
40	28.224	7.056	7.056
30	13.5	10.125	3.375
20	18.73	14.0475	4.6825
15	28.06	21.045	7.015

Band	LO	Center	Clk
160	7.3728	1.843	1.843
80	14.06	3.515	3.515
40	28.224	7.056	7.056
30	13.5	10.125	3.375
20	18.73	14.0475	4.6825
15	28.06	21.045	7.015

Theory of Operation

The dividers accept as input the output of the local oscillator and divide that down to two signals that are $\frac{1}{4}$ the input frequency and in quadrature (90° out of phase with each other).

U2 is wired as a divide-by-4 synchronous divider, clocked by the output from the Local Oscillator. Synchronous clocking means that all stages switch at the same time, potentially offering a reduction of noise generated during switching.

The divider provides two LO outputs which clock Mixer, U3.

Softrock Lite II – Op Amps

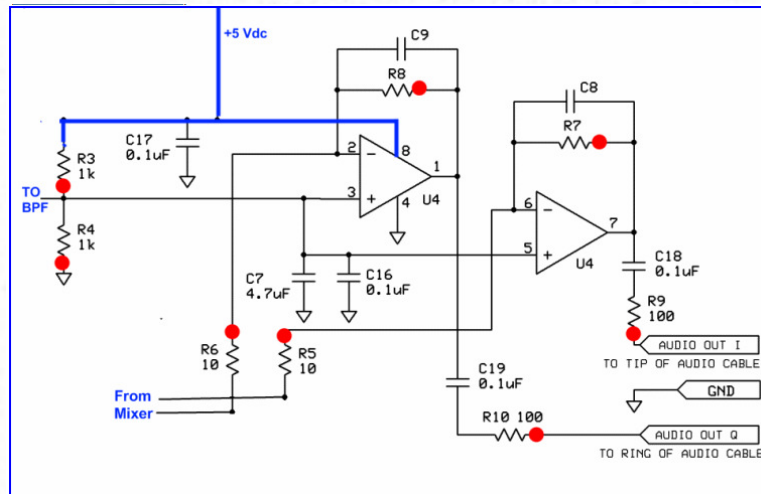

Theory of Operation

The low-level In-Phase (I) and Quadrature (Q) IF signals from the Mixer are sampled over capacitors C5 and C6.

The Opamp amplifies the I and Q signals by a factor 100 times on 160M, 80M and 40M bands and by about 500 times on 30M, 20M and 15M.

Higher gain and a low noise LT6231 Opamps are supplied for the three highest bands to compensate for additional loss due to 1/3 harmonic sampling and the fact that atmospheric noise is lower on these bands allowing for more sensitive receivers to be used.

Softrock Lite II – Band Pass Filter

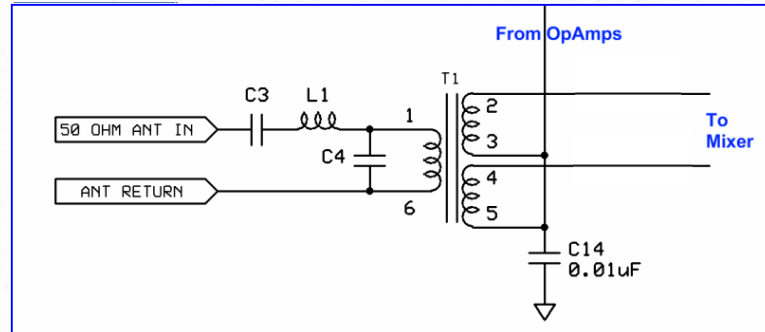

Theory of Operation

The purpose of this stage is to pass the Radio Signals within the receiver band to the mixer stage and to attenuate unwanted signals which are within the designed passband for the filter.

This attenuation is especially important, since it permits the 1/3 harmonic sampling in the mixer for the higher bands. Without that attenuation, for example, the 20m kit would be responding to signals in the region of 4.6825 MHz rather than to the designed response in the region of the 3rd harmonic of 14.0475 MHz!

Softrock Lite II – Mixers

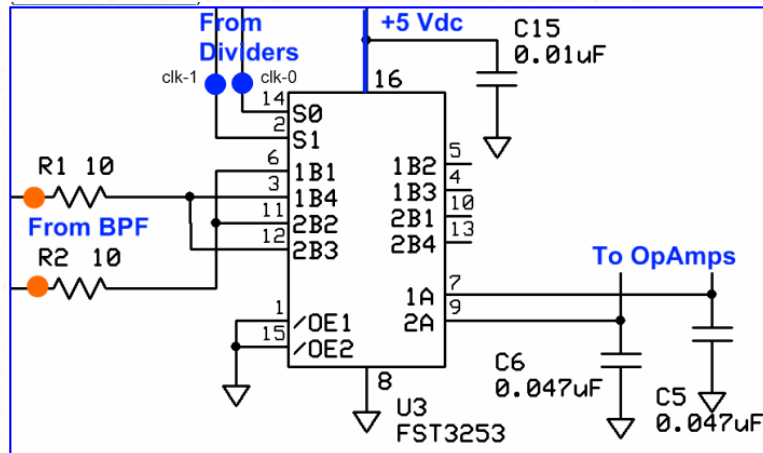

Theory of Operation

The RF input signal, filtered by the BPF is applied in antiphase to the inputs 1B and 2B of the Mixer U3.

The two LO signals from the Divider Stage operate the switches which connect R1 to C5 and connects R2 to C6 during the first clock cycle.

When the LO Clock changes 90 degrees later, the connections reverse: R1 now connects to C6 (Q) and R2 connects to C5 (I).

This switching sequence then repeats itself.

The resulting RF input signal is sampled over capacitors C5 and C6 as the Intermediate Frequency (IF)

On the lower bands (160m, 80m, and 40m) the dividers are clocked at the desired center frequency, which is in the pass band for the incoming RF.

On the higher bands, the situation in the Softrock RX is a little different. The clocking frequency is at the one-third sub harmonic of the desired center frequency and is NOT within the passband of the incoming RF.

SDR, just add software

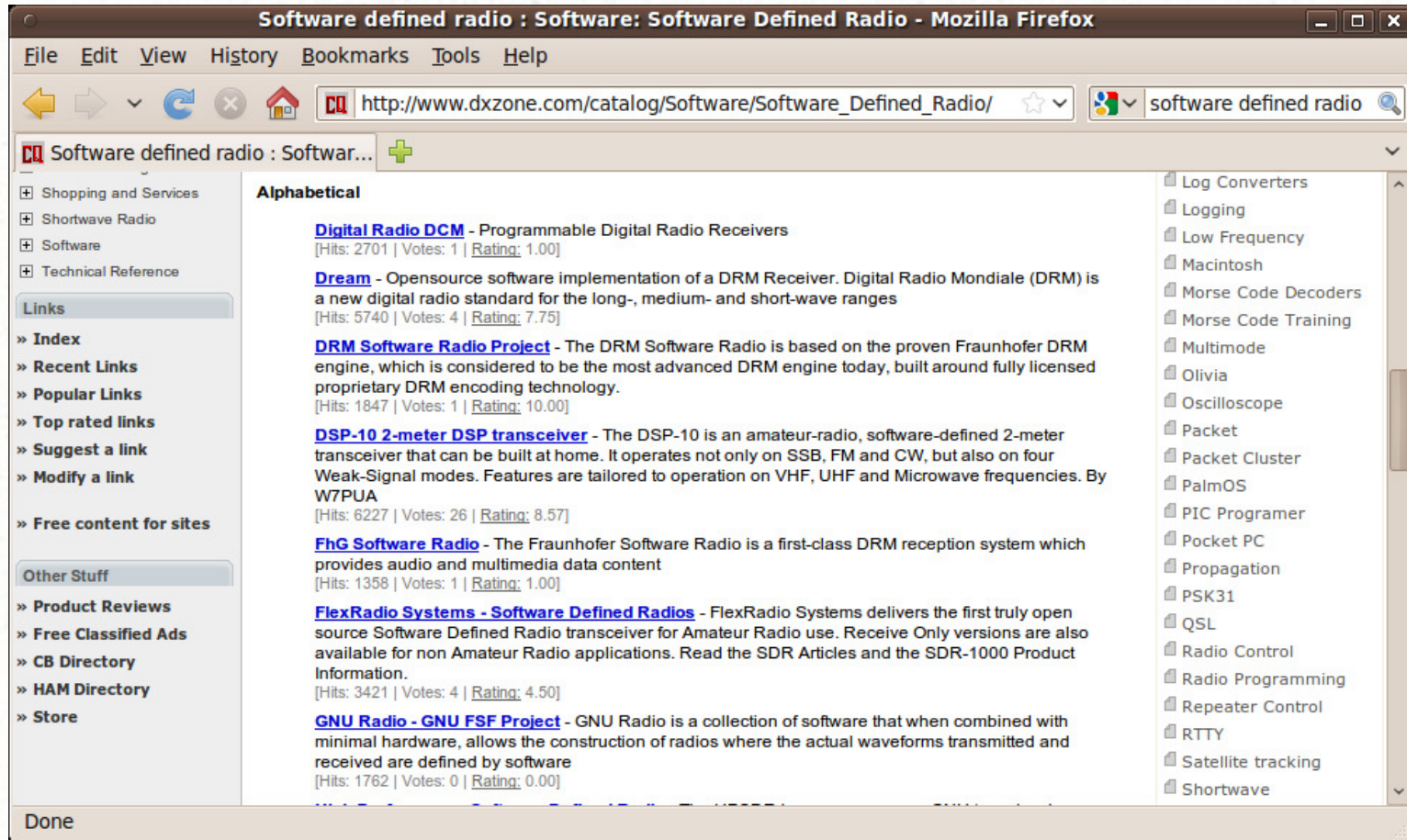

As with SDR hardware, there are many software choices; one list is at
http://www.dxzone.com/catalog/Software/Software_Defined_Radio/